

Statistical multiplex

– what does it mean for DVB-T?

Dr. Manfred Kühn, Dr. Jochen Antkowiak

In obtaining MPEG-coded programs with good subjective picture quality – despite the low data rate – the use of statistical multiplex is a conceivable solution. For this reason it was interesting to investigate the effect of statistical multiplex in a realistic, comparative test scenario in line with the marginal terrestrial broadcasting conditions. Here we will be looking at the methods used to analyze picture quality, actual measurement of picture quality and finally statistical evaluation of the results. The latter show that statistical multiplex does not in fact allow an increase in the number of programs transmitted per DVB-T channel. Nevertheless, the authors do consider the extra effort involved by statistical multiplex to be justified, because it effectively reduces something very specific to digital coding, namely the occasional, brief quality degradations that stem from picture content, thus suppressing a potential cause of subjectively unacceptable interference.

1. Preamble

In addition to program reception using directional roof antennas, terrestrial digital television, or digital video broadcasting (DVB-T), offers the possibility of portable and mobile reception with nondirectional antennas, although calling for higher received signal energy. And the transmitted energy cannot be elevated at random. Protection of existing analog television in particular means that transmitted power is limited.

Quite independently of this, for economic reasons, providers obviously want to broadcast as many programs as possible in a UHF channel, with the best possible quality of service, and over as large a coverage area as possible. Seeing as the total data rate is a function of available channel capacity, one has to try to keep the data rate for the individual programs as low as possible. This is contrary to the fact that the picture quality of a compressed program tends to be inversely proportional to the compression factor. In addition, the scene material, ie the content of the pictures to

be coded, influences picture quality. In other words, scenes containing pictures with a lot of detail and fast movement (often the case in sport broadcasts) need a higher data rate than scenes where pictures are low in detail and movement is slow (as in animated cartoons) in order to create a comparably satisfactory, subjective impression of quality in the eyes of the viewer.

The use of statistical multiplex [1, 2], despite low data rates, is a very promising approach to producing good subjective picture quality in MPEG-coded programs. It is based on the assumption that it is fairly unlikely that all programs comprised in the same multiplex will consist of critical scene material at precisely the same time. Therefore it is conceivable that an *intelligent* multiplexer will drive the output data rate of the encoders so that the one whose program momentarily makes the highest demands on the MPEG coding process is always instantaneously allowed the highest output data rate. This assumption is even truer, the larger the number of independent items of picture information (program data streams) that are added to a transport data stream in the multiplexer.

This is a condition that can hardly be met in a terrestrial DVB broadcast. Although the DVB-T standard permits transmission rates up to about 30 Mbit/s, one has to assume that as a rule total data rates of 11 to 22 Mbit/s will be common for DVB-T. That is particularly true in Germany where portable reception in buildings is a coverage objective, meaning selection of very robust transmission and error-correction parameters.

Enormous increases in capacity were forecast in part for cable and satellite channels through using this technique [2]. More recently, serious investigations show that statistical multiplexing of eight programs produces a clearly perceptible quality improvement, especially where critical picture scenes in programs are concerned [3]. The use of statistical multiplex in terrestrial DVB-T systems has been a contested topic so far.

For this reason it was interesting to **investigate** the effect of statistical multiplex in a realistic, comparative test in line with the marginal conditions of terrestrial broadcasting.

2. Test set-up

Deutsche Telekom has been participating in various experimental DVB-T projects or actually initiated them to make sure it is well prepared for the launch of digital terrestrial television as a regular service. Such projects look into the technical problems to be resolved in the leadup to migration from an analog to a digital terrestrial service.

The most extensive DVB-T project in Germany up to date was created in Greater Berlin with the support of the Berlin-Brandenburg Media Institute (MABB). Here Deutsche Telekom is currently transmitting 17 TV programs in five UHF channels. About another 8 Mbit/s are available for data services. The Free Berlin Broadcasting Corporation (SFB) is transmitting another three programs from the bouquet of ARD (Association of Public Broadcasters of Germany) on a further UHF channel.

The coding and multiplexing facilities of Deutsche Telekom for the DVB-T project were set up at the Winterfeldstrasse. This play-out center (POC) distributes the transport data streams, carrying service information (SI and EIT) and data services in addition to the coded picture and sound signals, to the various transmission points. Greater Berlin is presently covered by three single transmitters (C43, C46 and C53) in 2k mode and by two single-frequency networks (C51 and C59) in 8k mode.

Because of the concentration of the coding and multiplexing technology in the Berlin POC, it was fairly obvious that the planned comparison of quality should be carried out here, especially as all encoders and multiplexers originate from the same producer. In this way it was possible to ensure that the results would not be corrupted by quality differences between the instruments used.

Table I. DVB-T modes currently in use in Berlin-Brandenburg project

Channel	Modulation	CR	GI	Data rate (Mbit/s)	Content
43	16-QAM	1/2	1/8	11.06	Programs + data
46, 53	16-QAM	2/3	1/8	14.75	Programs + data
51	16-QAM	1/8	1/8	14.75	Programs
59	64-QAM	1/8	1/8	22.12	Programs

The Berlin-Brandenburg project currently works with the DVB-T modes listed in **Table I**. It can be seen that there are about 3.5 to 4.7 Mbit/s available for each

program. This means that there are three practical possibilities for channel occupancy in the tests to be conducted. These are illustrated in Table II. Taking all program components (picture, sound, program-accompanying data and service information) into account, only 3.2 and 4.4 Mbit/s respectively remain for the compressed video signal.

Table II. Data rates for terrestrial broadcasting

Table II. Data rates for terrestrial broadcasting						
	3 programs in 11.06 Mbit/s (16-QAM, CR = 1/2, GI = 1/8)		3 programs in 14.75 Mbit/s (16-QAM, CR = 2/3, GI = 1/8)		4 programs in 14.75 Mbit/s (16-QAM, CR = 2/3, GI = 1/8)	
Program component	Per program [Mbit/s]	Total rate [Mbit/s]	Per program [Mbit/s]	Total rate [Mbit/s]	Per program [Mbit/s]	Total rate [Mbit/s]
Picture	3.2	9.6	4.4	13.2	3.2	12.8
Sound	0.192	0.576	0.192	0.576	0.192	0.768
Data (Teletext)	0.224	0.672	0.256	0.786	0.256	1.024
Service information	---	0.128	---	0.128	---	0.128
Total		10.98		14.69		14.72

As already mentioned, comparable conditions were to be created for the tests, in terms of both constant and statistical multiplex. Consequently, two multiplexers with four encoders each were chosen from the POC's inventory. The test setup is outlined in **Fig. 1**. The same programs (V1, A1 through V4, A4) were applied to the encoders (V CD, A CD) in each multiplexer (MUX). The compression rates of the encoders of the statistical multiplexer were set the same for all programs. The same mean data rate was chosen for all programs in statistical multiplex as set in constant multiplex as a constant data rate for the programs. In addition, the limits for maximum and minimum data rate of the statistical multiplexer were also set the same for all programs.

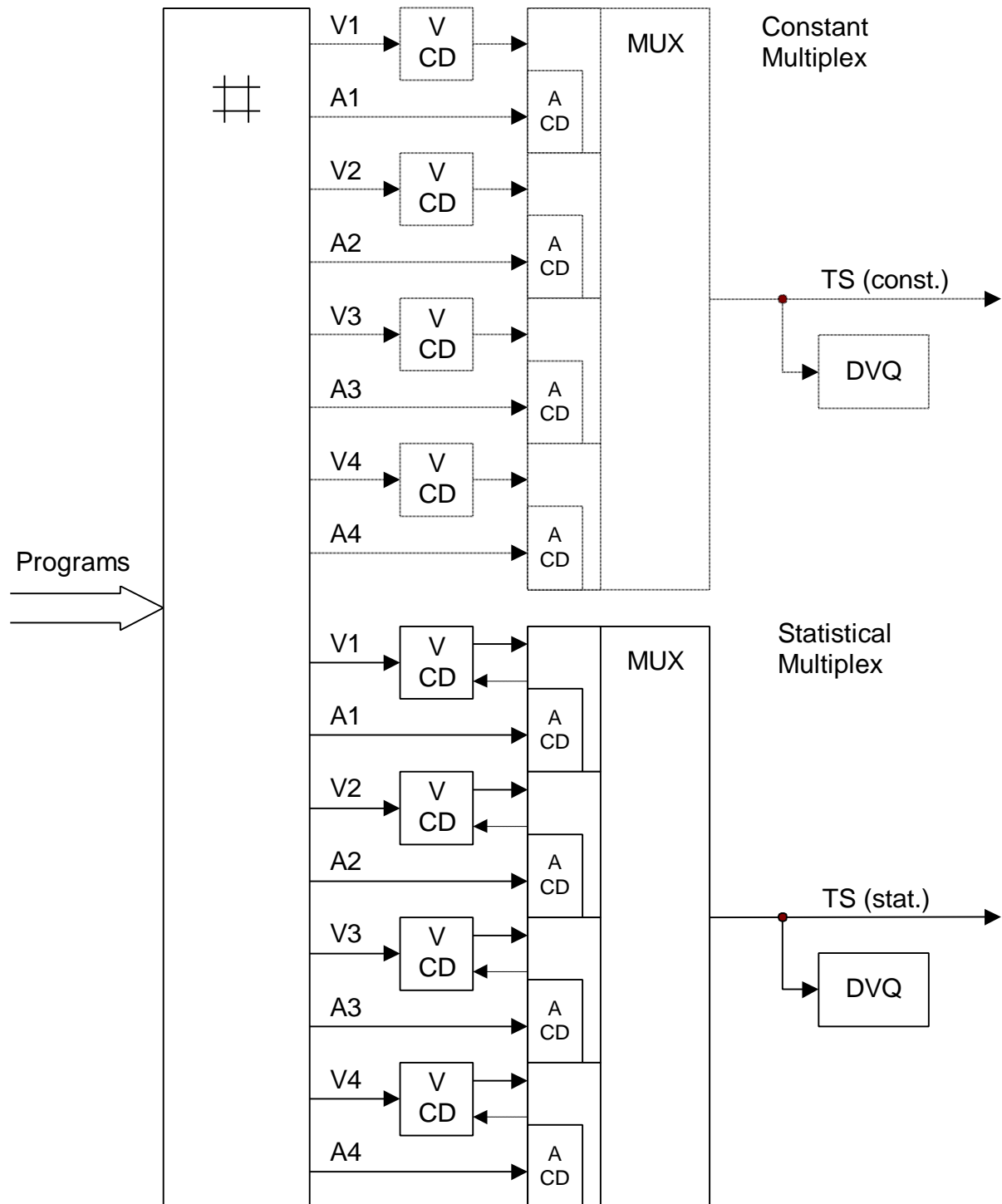

Fig. 1: Test set-up

The resulting transport streams (TS const. and TS stat.) were fed to both the transmitters and video quality analyzers of the type *DVQ*, which selected the video data stream to be analyzed. PCs were linked to the serial interfaces of these instruments for recording their measured data and subsequent further analysis (see Section 5).

3. Methods of measurement for picture quality analysis

There are tried and tested methods, standardized in a number of ITU recommendations, for subjectively assessing the quality of video picture material. Rec. BT.500-9 is particularly familiar, which regulates the basics of such assessments. Although such subjective methods of assessment produce respected and reliable measured data, this comes at the expense of extremely elaborate tests in terms of technical preparations, test persons involved and statistical conditioning of the data. Subjective tests allow neither concurrent results nor long-term observations.

So for the task at hand in this case, ie constantly measuring and comparing the picture quality of at least two programs for several hours, the solution had to be an instrument-based method.

Sufficiently accurate modelling and implementation of the human visual system for assessing quality in a technical measuring system is very difficult, so currently there is not a great choice of test equipment on the market. In addition, there was a requirement for realtime capability plus independence from the picture material to be tested. Consequently the newly developed *Digital Video Quality Analyzer DVQ* from [Rohde & Schwarz](#) was used, which promised the performance called for [4, 5].

Before actual use of this new instrument to assess picture quality, tests were first conducted to verify the capabilities of the method and the validity of its results. As an example of such investigations, **Fig. 2** shows a test series with seven repetitions of a 15 s segment of the *Susie* sequence. They were recorded as an original (ITU-R.601), after PAL coding, after VHS recording, and after MPEG coding with different code rates on a D1-DCR. A constant grey level separates the individual scenes for 5 s. The DVQL-W picture quality parameter (blue line) exhibits a plausible response for the MPEG2-coded sequences.

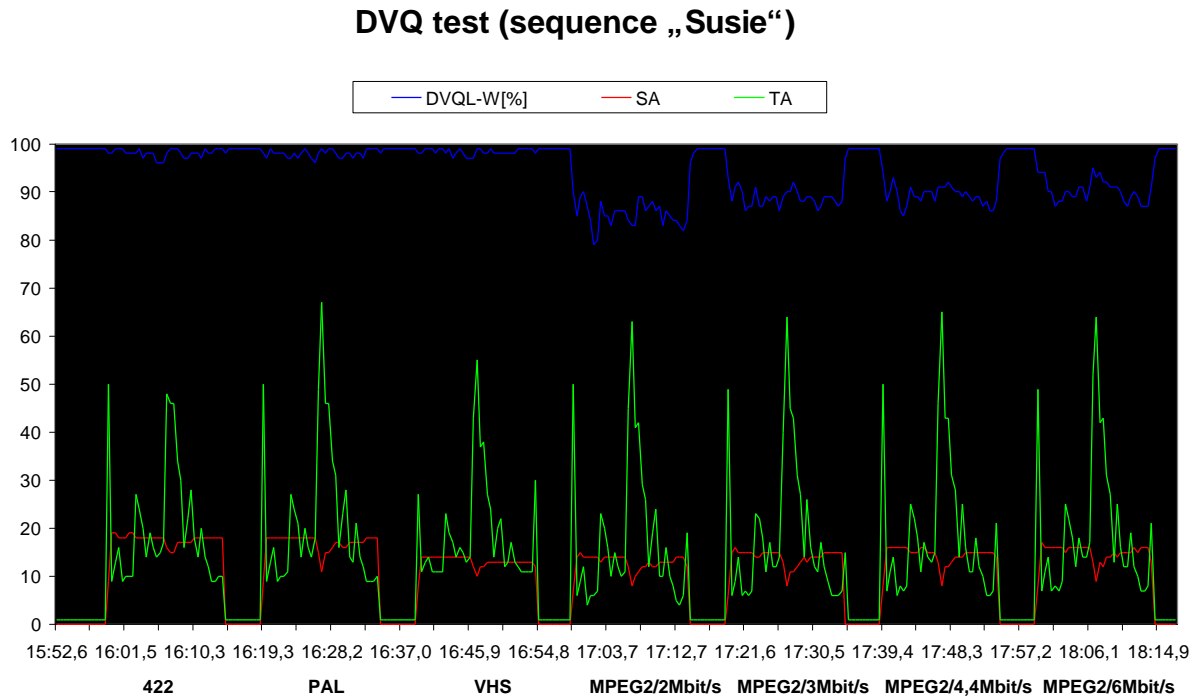

Fig. 2: DVQ (test sequence „Susie“)

It can be seen that the DVQL-W value increases with data rate. This is not the case in the original and the analog formats. Which is not surprising, because the method of measurement used by *DVQ* is essentially based on detection of interfering effects at the edges of the blocks formed by the coding process and their physiological evaluation. So one can only expect accurate quality data of *DVQ* if the signals are subjected to a block-based coding process. The curves of spatial and temporal activity (SA and TA), ie resolution of detail and motion, which are also shown in Fig. 2, are remarkable in being correct in all cases. Overall these preliminary investigations demonstrated that *DVQ* would deliver sufficiently precise and reproducible measured data of the picture quality of DVB signals for the intended purpose.

4. Performance of picture quality measurements

A large number of long-term measurements with observation phases of between three and 45 hours were carried out with the test setup of Fig. 1 and the test scenarios of Table II. The DVQs produce a new data record about every 444 ms with the current figures for picture quality, the two activities (SA and TA) as well as the video data rate of the program data stream (PS) selected and decoded from the transport stream (TS). A typical curve of the video quality parameter (DVQL-W) is shown in Fig. 3. The values measured for constant multiplex (red) and statistical multiplex (blue) appear one above the other, making them simple to compare. The curves are virtually identical for a lot of the time, meaning that one cannot expect any serious differences between the two quality curves as a long-term mean. But what are striking are the brief but deep quality dips in conventional multiplex (red curve). These are damped appreciably in the case of statistical multiplex, as demonstrated by the very seldom visible minima of the blue curve. The green bitrate curve illustrates very impressively how the statistical multiplexer reduces the deep quality dips by providing extra data rate.

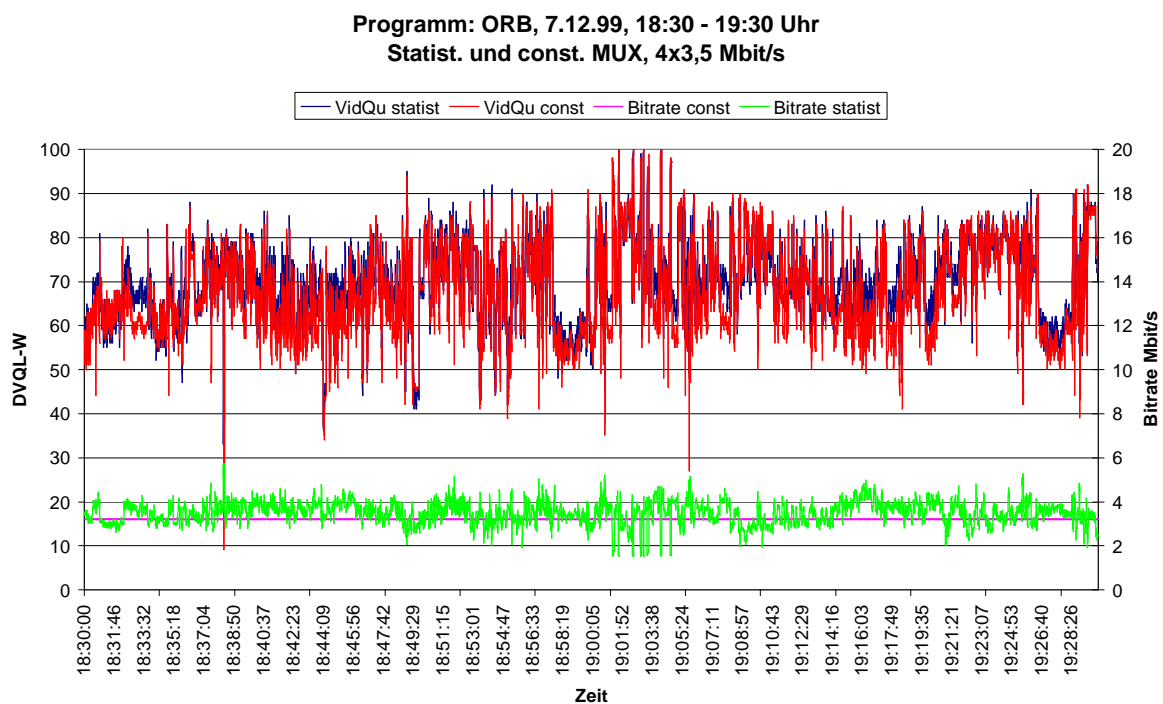

Fig. 3: Long-term analysis of picture quality and data rate

Fig. 4 is a six-minute segment of the curves in Fig. 3. The higher time resolution makes the effects described above more visible. This is confirmation of how statistical multiplexing damps the quality minima. The quality of statistical multiplex is sometimes even higher than the DVQL-W figure determined for multiplexing with a constant bit rate. Here the bit rate of the variable encoder is increased for an appropriate period. It is likely that at this point the competing programs require little data rate because of their uncritical scenes.

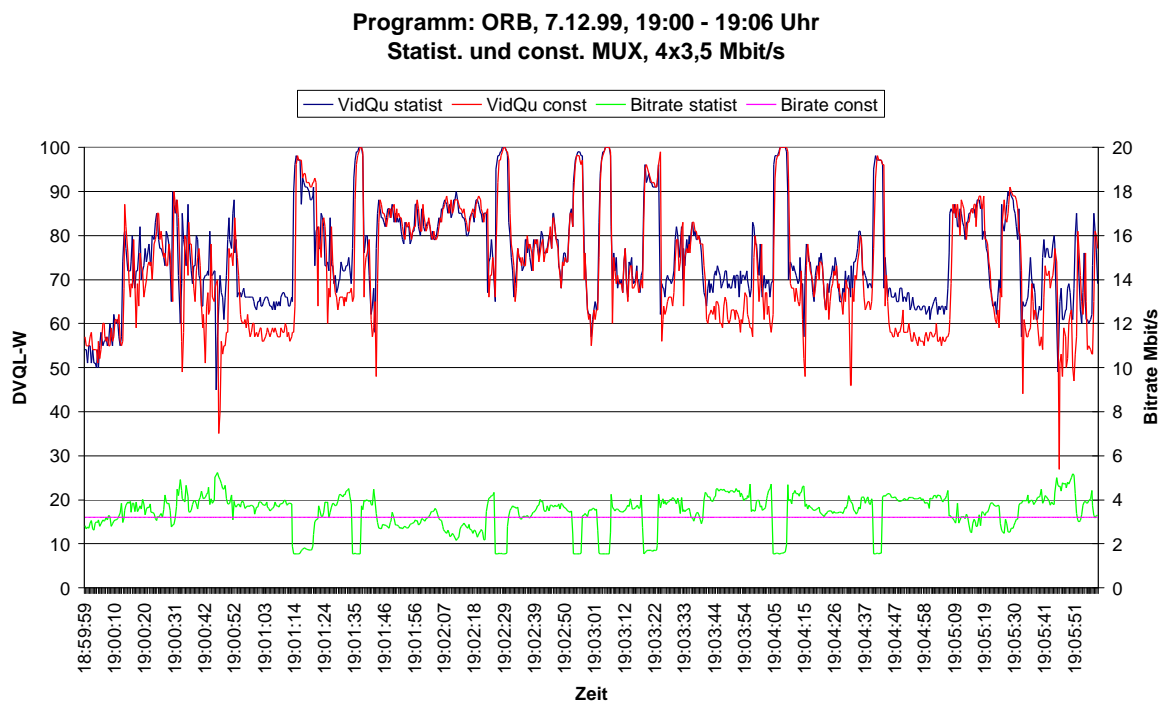

Fig. 4: Long-term analysis of picture quality and data rate (segment)

The curves of picture quality show very considerable fluctuations in their progress. This is true of both the brief, strong fluctuations within the scenes of a broadcast item and the marked differences in the level of mean quality for different broadcast items. Statistical multiplex seems to reduce brief, deep quality dips in the MPEG-coded program data streams. But improvement in the long-term stability of picture quality to a constant level cannot be guaranteed, ie at least with the present state of the art.

The measurements were in some cases repeated after terrestrial broadcasting with the received program data streams. With interference-free reception (after error correction) the measured results were virtually identical

5. Statistical evaluation of results

Because of the considerable fluctuation in the values measured, and the substantial quantity of data after just a short period of measurement, one is compelled to look for general evidence of quality using statistical analysis. The simplest way is averaging with time, and has already produced interesting results (Fig. 5).

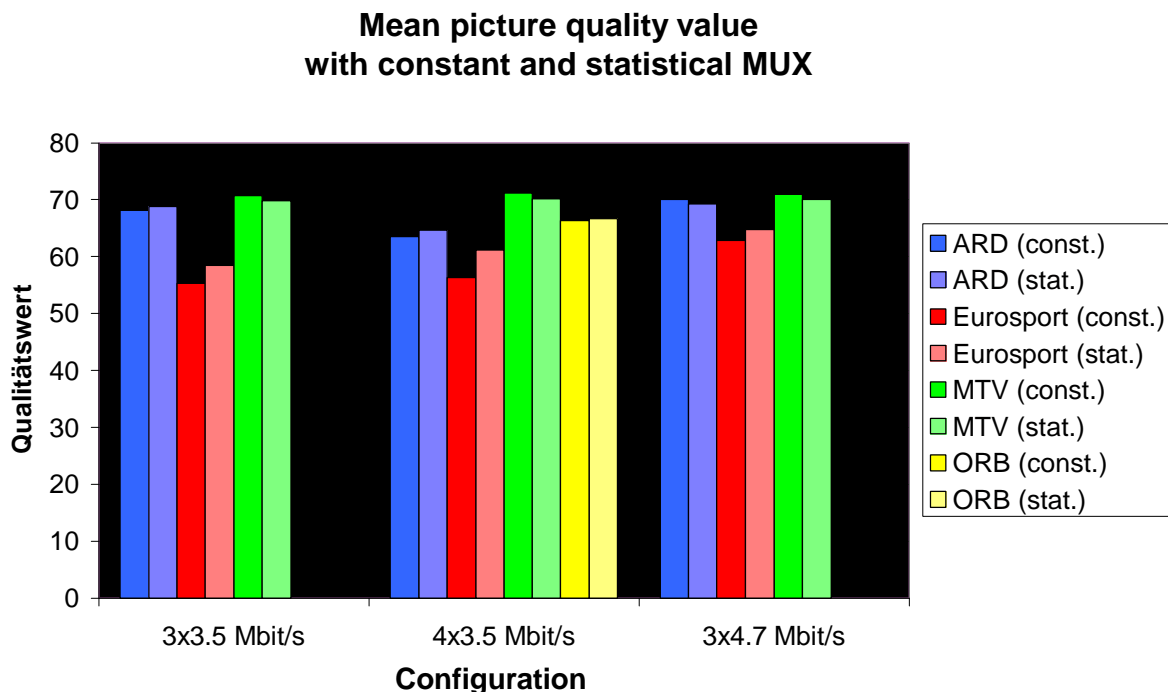

Fig. 5: Comparison of mean picture quality in constant and statistical multiplexing

Here the mean picture quality values for constant and statistical multiplex are shown next to one another in columns of the same colour. The three or four TV programs occupying a channel form a group of columns. It can be seen clearly that the mean picture quality of almost all programs barely alters through statistical multiplex (calculating with the human perceptibility threshold for differences in quality). The Eurosport program is an exception, where both the use of statistical multiplex and the increase in program data rate leads to an improvement of mean picture quality. This seems to be quite consistent with the long known fact that precisely sport scenes are especially critical in terms of bit rate restrictions in digital coding.

Fig. 5 also demonstrates why, at least in the case of DVB-T, where only a few programs can be multiplexed at a time, the number of programs per channel can

hardly be increased by using statistical multiplex – a degradation of the mean picture quality of a program through inevitable reduction of its data rate when more programs are inserted cannot be compensated for.

Mere consideration of the simple arithmetic mean of measured picture quality values is not enough to assess the effect of quality fluctuations on the subjective perception of picture quality in more detail. In the case of temporary interfering influences, the nonlinear processing of short, isolated quality degradations (these are assessed negatively more than proportionally) and the effect of how such interference is gradually forgotten (a time constant of about 26 s can be assumed) both play a role [6].

For these reasons, analysis of the measured data for maintenance of a given lower quality limit was subsequently performed. For each multiplexer configuration those quality readings were counted that went below a figure of 20, thus putting them into the category of "very poor" subjective quality. From this the time was determined during which a visible lack of quality cannot be ruled out. **Fig. 6** shows the results. This is where the positive effect of statistical multiplex really makes an impression. One finds almost perfect suppression of the brief quality degradations that have a strongly disturbing subjective impact.

Rate of occurrence of reduced picture quality in constant and statistical MUX

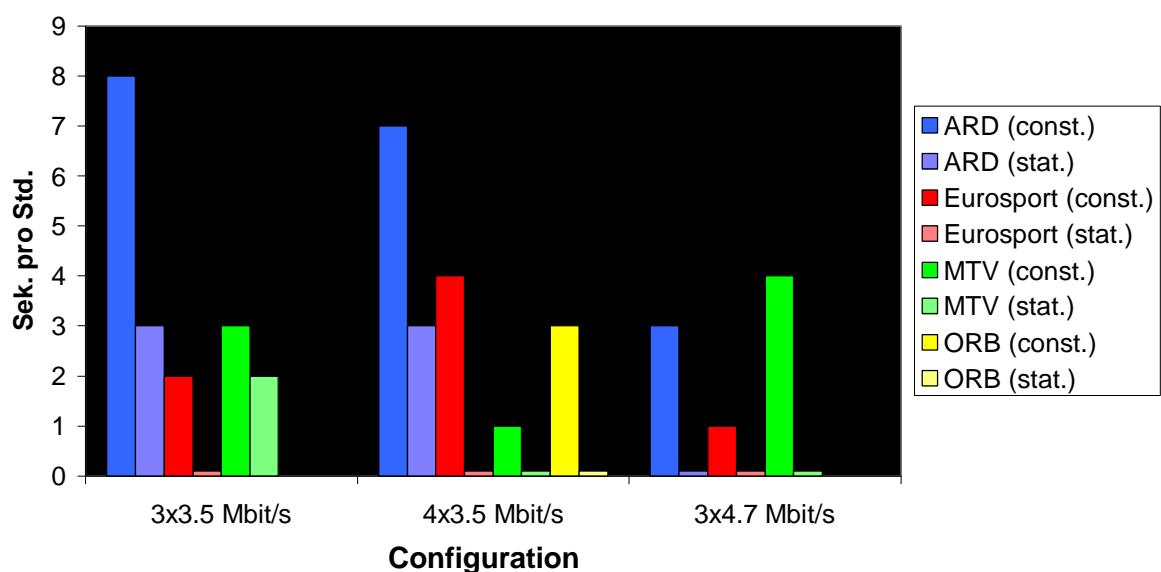

Fig. 6: Rate of occurrence of reduced picture quality in constant and statistical multiplexing

To avoid any misinterpretation of the results, one should not overlook the following two facts. Although it is broadcast with relatively few quality dips (Fig. 6), the Eurosport program is on average of relatively low picture quality (Fig. 5). And some of the quality dips in the ARD program in Fig. 6 can be traced to switching operations during afternoon changeover to regional broadcasters and consequently entered into the assessment.

6. Summary and assessment of results

The *Digital Video Quality Analyzer DVQ* from Rohde & Schwarz is suitable for monitoring the quality of the picture content of DVB-T signals. It shows at least the relative quality differences of MPEG2-coded video signals in their subjective effect with sufficient accuracy.

The picture quality readings are subject to a very wide span of fluctuation. So they must be checked over longish periods of time. Statistical analysis of the measured data is necessary before conclusions regarding possible error causes and measures for improving picture quality can be derived.

The program data rate assigned to a single TV program in a multiplex should go by the program type. In this way, by steering the individual program data rates of all programs in a bouquet, it is possible to ensure a comparable impression of quality.

Using statistical multiplex will not increase the number of programs transmitted per DVB-T channel. Statistical multiplex is only able to improve the mean quality of programs with very critical picture content over longer periods of time.

Nevertheless, the extra effort involved by statistical multiplex is justified, because it effectively reduces something very specific to digital coding, namely the occasional, brief quality degradations that stem from picture content, thus suppressing a potential cause of subjectively unacceptable interference.

The Authors

Dr. Manfred Kühn from the broadcast division of Deutsche Telekom AG is responsible for the development of terrestrial networks.

Dr. Jochen Antkowiak from T-Nova Berkom deals with acceptance and quality assessments of new services.

References

- [1] Huang, S. J.: Variable Bitraten-Codierung für digitale Videoübertragungssysteme. FKT 53 (1999) no. 10, pp 571-579
- [2] Hofmeir, S.: Pro Kanal 24 TV-Programme. Funkschau (1996) no. 36, pp 55-57
- [3] Schertz, A.: Usefulness of Statistical Multiplexing. Second International Workshop on Quality of Service in Digital Television, ORT, ZEIT
- [4] Lauterjung, J.: Picture Quality Measurement. Proceedings of the International Broadcast Convention 1998. Amsterdam, September 1998
- [5] Wörner, A.: Digital Video Quality Analyzer DVQ – Getting the picture on picture quality. News from Rohde & Schwarz 39 (1999/III), no. 163, pp 4-7
- [6] Hamberg, R.; de Ridder, H.: Time-varying Image Quality – Modeling the Relation between Instantaneous and Overall Quality. J SMPTE (1999), no. 11, pp 802-811

Credits

Reprint by courtesy of FKT, Die Fachzeitschrift für Fernsehen, Film und Elektronische Medien – Offizielles Organ der Fernseh- und Kinotechnischen Gesellschaft, Hüthig-Verlag, Heidelberg, Issue April 2000.